



Hollow-Piston Cylinders

Version with internal thread

single and double acting, max. operating pressure 500 bar



Advantages

- 6 sizes available
- Single or double acting optionally
- Pull force up to 188 kN
- Push force up to 153 kN
- Piston with through hole
- Internal thread for fixing threaded rods or contact bolts
- Conversion of existing fixtures to hydraulic clamping
- Many installation possibilities

Single acting with spring return

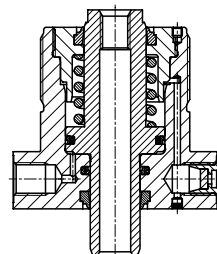

Double acting

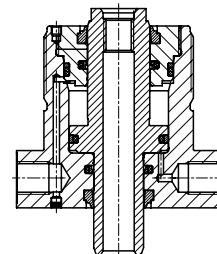

Application

Hollow-piston cylinders are especially suitable for clamping workpieces that have a through hole or opening.

Description

The piston has a through hole with an internal thread. In connection with a standard tie rod and C-washer combination a variety of applications is possible (see application examples). After the workpiece has been inserted and centred by hand, the C-washer can be pushed onto the tie rod and then clamped hydraulically. Compared to mechanical clamping with clamping screws this has significant advantages:

- The clamping force can be hydraulically adjusted with precision and high repetitive accuracy.
- The operator can fully concentrate on the correct position of the workpiece.
- A significant time saving.

Equipped with a contact bolt (see data sheet G 3.800), the hollow piston cylinder can also be used for direct die clamping. The piston thread can be drilled open, if required.

If the hollow-piston cylinder is mounted onto movable parts, e.g. clamps, the hydraulic oil has to be supplied through a high-pressure hose.

Important notes

For operating pressures exceeding 350 bar only bolts, studs, or screws of material 10.9 must be used.

It is important to torque the lock nut used sufficiently to prevent damaging the piston threads. Penetration of aggressive cutting lubricants and coolants through the sintered metal air filter into the cylinder's interior should be avoided by appropriate arrangement or covering.

Operating conditions, tolerances and other data see data sheet G 0.100.

When using single-acting hollow-piston cylinders, it is absolutely necessary to follow the instructions for bleeding of the spring area on data sheet G 0.110.

Installation possibilities

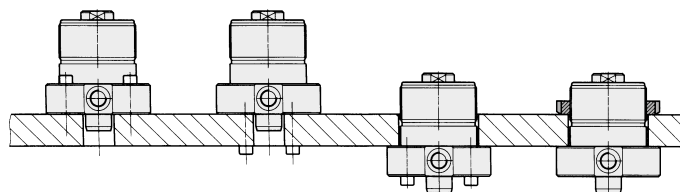

1752 004/023
1754 004/023
1755 004/023

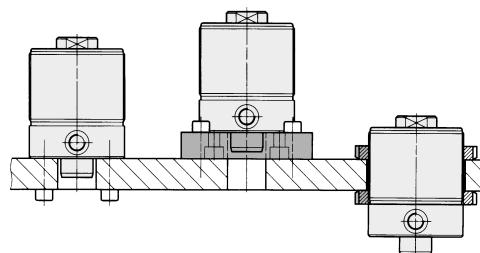

1756 004/023
1757 004/023
1758 004/023

Application examples

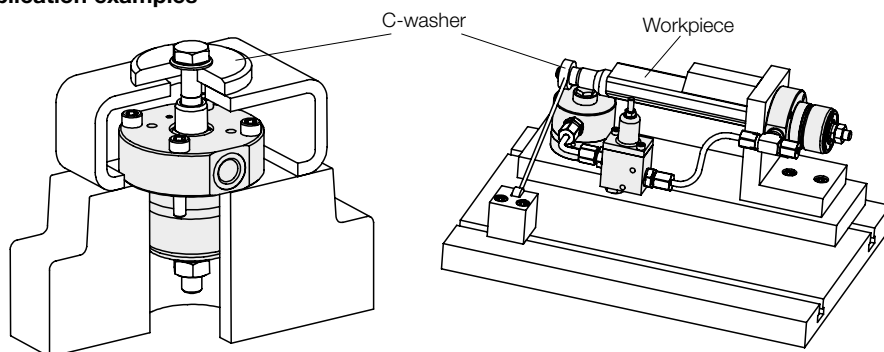

Hollow-piston cylinders in combination with push-pull bolt and "C"-washer can be used advantageously in many cases to clamp workpieces with centre openings.

On the machine table, the workpiece is additionally supported by means of a work support in combination with a sequence valve (as per data sheet C 2.954).

The support plunger of the work support is retracted in off-position to facilitate workpiece loading. Contact is effected by means of spring force.

Compared to mechanical clamping, a time saving of 60% is achieved.

Technical data

Version 1

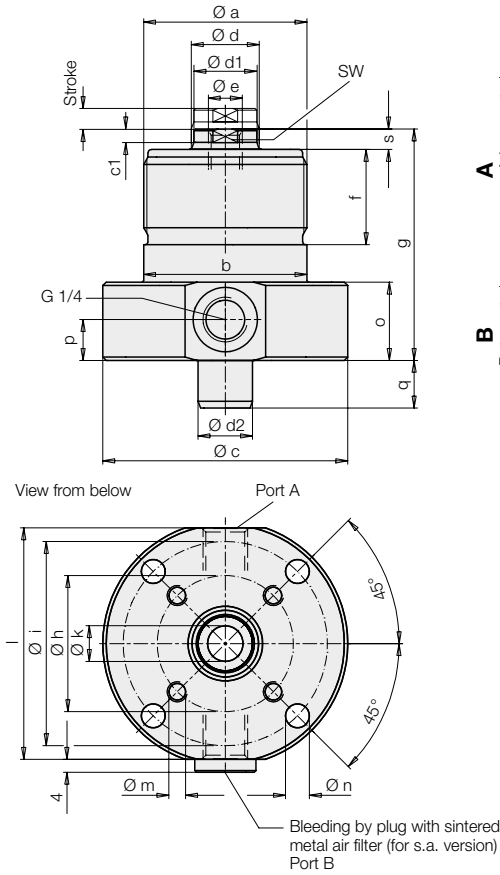

Version 2

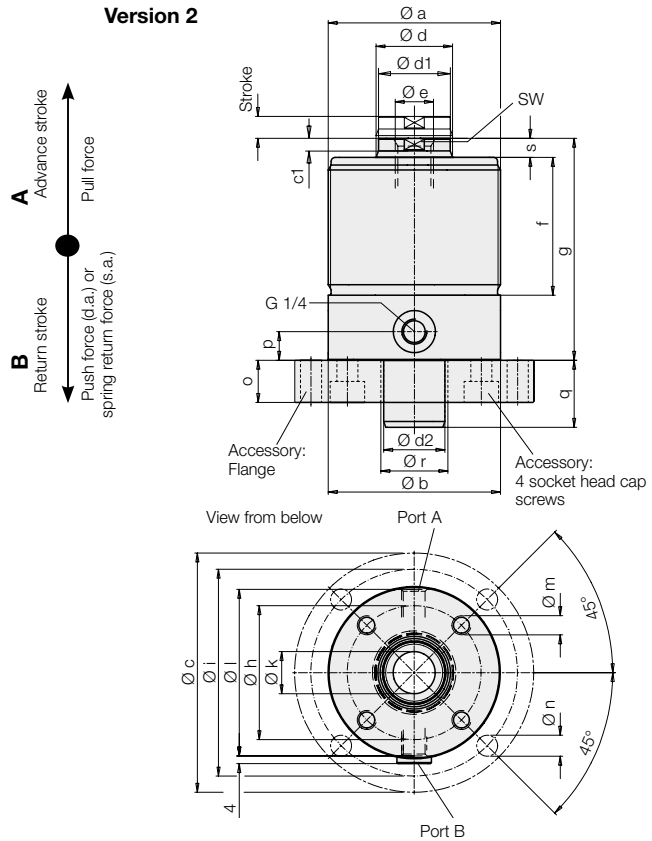

Version		1	1	1	2	2	2
Piston diameter	[mm]	20	32	40	50	63	80
Pull force 100 bar	[kN]	2	6	9.4	14.7	23.1	37.7
Pull force 500 bar	[kN]	10	30	47	73.6	115.6	188.5
Push force 100 bar (d.a.)	[kN]	2	4.8	7.6	11.9	18.6	30.6
Push force 500 bar (d.a.)	[kN]	10	24	38	57.9	93	153
Spring return force (s.a.)	[kN]	0.09	0.2	0.27	0.38	0.47	0.95
Piston area - stroke	[cm ²]	2.01	6.03	9.42	14.73	23.13	37.7
Piston area - return stroke	[cm ²]	2.01	4.89	7.65	11.58	18.6	30.61
Oil volume per 10mm stroke	[cm ³]	2.01	6.03	9.42	14.73	23.13	37.7
Oil volume per 10mm return stroke	[cm ³]	2.01	4.89	7.65	11.58	18.6	30.61
Ø a	[mm]	M40x1.5	M48x1.5	M60x1.5	M75x1.5	M90x2	M120x2
Ø b	[mm]	-	48	60	75	90	120
Ø c	[mm]	65	72	85	105	125	160
Ø d	[mm]	12	20	25	32	40	50
Ø d1 x c1	[mm]	11x3.6	18.5x3.9	23.5x4.9	29.8x6	37.5x6.5	47.5x6.5
Ø d2	[mm]	12	16	20	25	32	40
Ø e x depth of thread	[mm]	M6x8	M10x12	M12x15	M16x20	M20x25	M24x30
f	[mm]	30	28	34	60	72	100
g	[mm]	58	68	80	94	116	137
Ø h	[mm]	30	40	50	60	70	98
Ø i	[mm]	52	60	72	90	108	140
Ø k	[mm]	6.5	10.5	12.5	16.5	21	25
Ø l	[mm]	60	68	82	72	87	117
Ø m x depth of thread	[mm]	M6x8	M6x8	M6x10	M8x10	M10x14	M12x15
Ø n	[mm]	7	7	7	9	11	13.5
o	[mm]	23	23	23	20	22	25
p	[mm]	12	12	12	12	15	15
q	[mm]	12	14	19	23	35	43
Ø r	[mm]				28	35	43
s	[mm]	5	6	7	9	10	10
SW	[mm]	10	17	22	27	36	46
Weight	[kg]	0.8	1.1	1.8	2.5	4.4	9.7

Single acting with spring return		6	8	10	12	16	20
Stroke	[mm]						
Part no.		1752004	1754004	1755004	1756004	1757004	1758004

Double acting		10	12	16	20	32	40
Stroke	[mm]						
Part no.		1752023	1754023	1755023	1756023	1757023	1758023

Accessories							
Flange					3456310	3456313	3456312
Socket head cap screw					3301263	3300277	3300054
Lock nut/DIN 1804/thread		M40x1.5	M48x1.5	M60x1.5	M75x1.5	M90x2	M120x2
Part no.		3300699	3300324	3300411	3300673	3300412	3300134