

CLAMPING FLAT
MACHINE
ELEMENTS.

HYDRAULICALLY
ACTUATED
CLAMPING STRIPS,
CLAMPING DISCS,
CLAMPING
CASSETTES AND
CLAMPING RINGS.



CLAMPING FLAT MACHINE ELEMENTS.

The principle: A lightning-fast grip and a powerful hold

KOSTYRKA clamps for flat machine elements clamp pallets, slides, stays, supports, tailstocks, turrets and much more. Their very high clamping forces are impressive, they react extremely quickly, are extraordinarily compact and require practically no maintenance. In short: KOSTYRKA® clamping strips, clamping discs and clamping rings are ideal for use in modern particularly efficient machine tools.

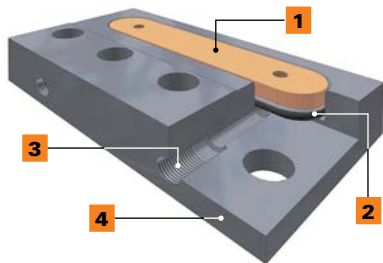

Kostyrka® clamping strips and clamping cassettes for holding and releasing e.g. slides.

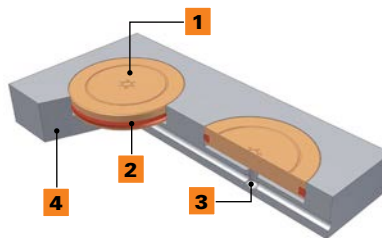

Kostyrka® clamping discs and clamping cassettes for holding and releasing e.g. tailstocks.

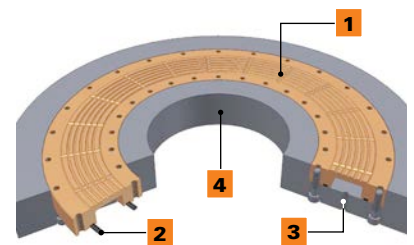

Kostyrka® clamping rings and clamping cassettes for holding and releasing e.g. turntables.

- 1** Clamping strip
- 2** Seal
- 3** Oil infeed
- 4** Clamping cassette

- 1** Clamping disc
- 2** Seal
- 3** Oil infeed
- 4** Clamping cassette

- 1** Clamping ring
- 2** Seal
- 3** Oil infeed
- 4** Clamping cassette

Fundamentals

KOSTYRKA's aim is to be a competent partner to its customers as early as in the design process, and to support them with advice.

The following section is therefore intended to illustrate on a practical basis the relationships between clamping forces and clamping surfaces, and in so doing help to optimally use the KOSTYRKA clamps for flat machine elements.

Calculating the clamping force F_K

After pressure is applied onto the clamping strip or clamping disc, the normal force F_{NB} is produced on the clamping surface B, and the counterforce F_{GA} is produced on the opposite surface A.

Due to the fit clearance, which would impair precise positioning of the part being clamped, clamping strips and clamping discs must not be subjected to any laterally-acting forces.

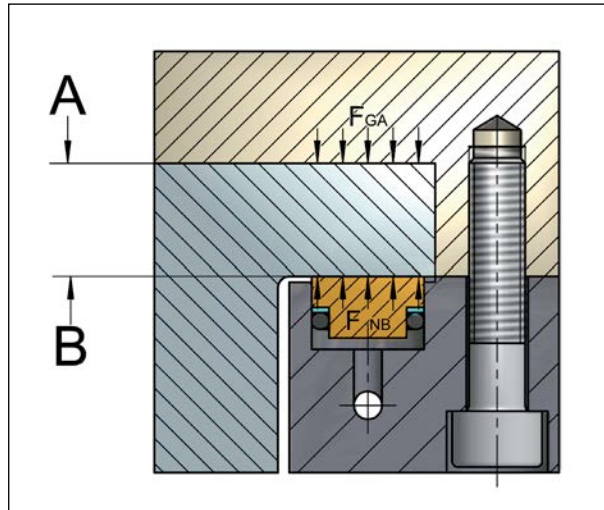

For this reason, it is not the normal force F_{NB} that is used to determine the clamping force F_K but instead only the counterforce F_{GA} arising on the opposite surface A.

This means that the following applies to determining the clamping force F_K that counters, for example movement of the slide on the guide bed:

$$F_K = F_{GA} \cdot \mu_A$$

F_K = clamping force; F_{GA} = counterforce;
 μ_A = friction factor of the opposite surfaces

THE KOSTYRKA® CLAMPING STRIPS.

How they work

When pressure is applied, the KOSTYRKA® clamping strip is pushed out of its recess like a piston, moves up to and against the element being clamped and presses it against the clamping surface. This pressure application greatly compresses the seal. The seal resumes its original shape again after the oil pressure is completely removed. This relative movement causes the clamping strip to be released from the clamping surface. This stroke is approximately 0.02 - 0.04 mm. If large strokes are required, spring assemblies can be used. Please contact the KOSTYRKA Development Department for further information.

The main advantages of this principle: Clamping strips respond immediately, clamp very powerfully and with minimum wear, and meet designers' requirements thanks to the extraordinarily small amount of space they take up.

General tolerances

All designs and sizes of the KOSTYRKA® clamping strips normally have the following tolerances:

Length L -0.03 / -0,06mm

Width W -0.02 / -0.04mm

Height H -0.01mm

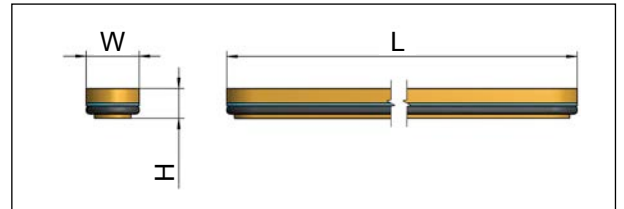

Custom dimensions and clamping forces

KOSTYRKA® clamping strips are designed and manufactured to customer-specific requirements. A large number of variants is possible, e.g. return springs for larger strokes, stop bevels or press-out safeguards. Contact our Development Department for details.



Materials

The clamping strip is usually made out of brass. If desired, the clamping strips can also be made from nitrided steel or surface-hardened aluminium.

Operating conditions

All designs of the KOSTYRKA® clamping strips are intended for operation with pressure oil. However, they can in all cases be used with all liquid media to which the body and the seals are chemically and thermally resistant. These include hydraulic fluids and petroleum-based lubricants, transmission oils as well as animal and vegetable fats in the range -30°C to +110°C. Higher operating temperatures are possible with VITON® seals if required.

The maximum working pressure for KOSTYRKA® clamping strips is 450 bar. Contact our Development Department for details if you require higher pressures.

However, activation with oiled compressed air is possible for transmitting low forces.

Installation requirements

The cutout for KOSTYRKA® clamping strip can be made by the customer without any difficulty, whereby the surface roughness of the cutout edges must not exceed $R_{\max} = 6 - 10\mu\text{m}$ ($R_a \leq 1.6\mu\text{m}$).

The tolerance of the cutout length L and width W is $+0.02 / +0.06\text{mm}$ respectively. The cutout must be at least 2 mm deeper than the height H of the clamping strip.

To prevent the O-ring from shearing off during installation, it is essential to provide a 20° lead chamfer of sufficient size that runs all the way round.

Besides the oil supply, a vent hole must also be provided for venting.

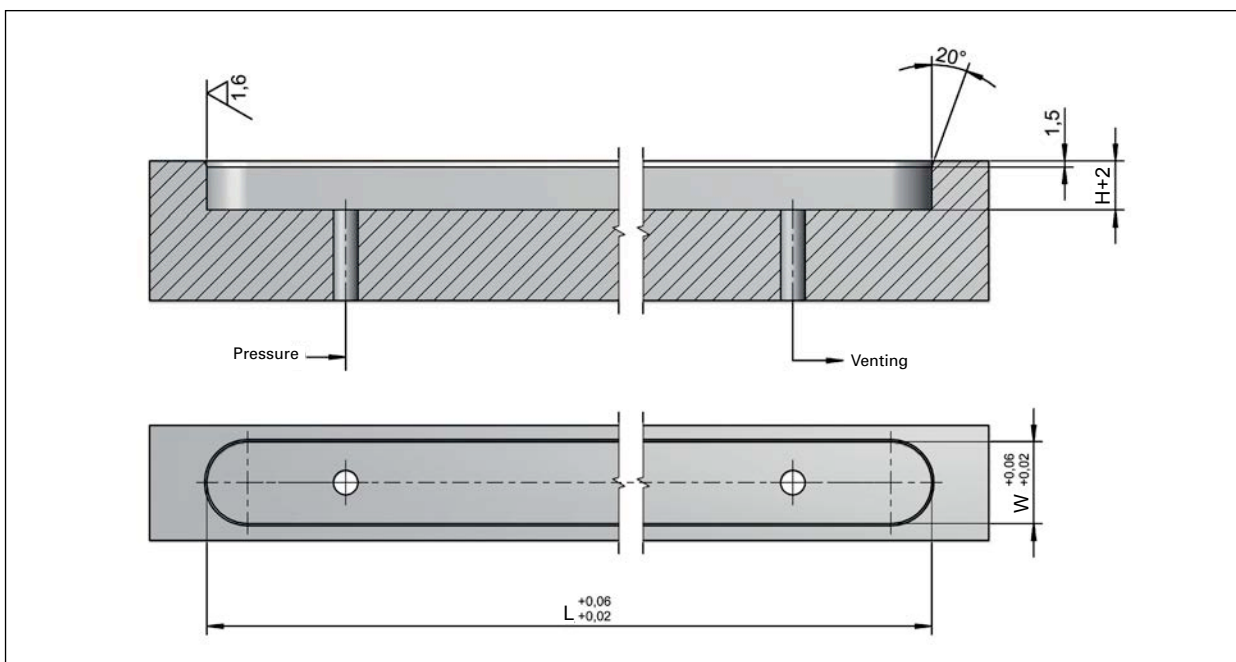

THE KOSTYRKA® CLAMPING DISCS.



How they work

KOSTYRKA® clamping discs essentially work in the same way as the clamping strips.

When pressure is applied, the KOSTYRKA® clamping discs are pressed out of their locating holes like pistons, move up to and against the element being clamped and clamp it firmly. After the oil pressure has been completely removed, the clamping discs move back about 0.01 mm without the seal moving in the locating hole. There is practically no wear. This guarantees fault-free operation combined with maximum service life.

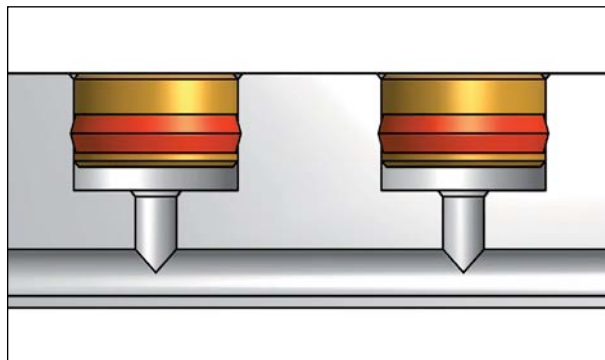

Installation of KOSTYRKA® clamping discs.

Materials

The clamping discs are made from bronze and are supplied with a seal. If desired, the clamping discs can also be made from nitrided steel or surface-hardened aluminium.

Dimensions / clamping forces

Since there are hardly any limits to the design possibilities of these elements, we constantly have a small selection of sizes in stock as standard. Special dimensions that differ from these are made to the customer's specific requirements. The standard dimensions kept in stock and those that are available at short notice are shown in the table below.

Type no.	D	H
5650.16	16 mm	8 mm
5650.22	22 mm	8 mm
5650.28	28 mm	8 mm
5650.32	32 mm	8 mm
5650.42	42 mm	8 mm
5650.52	52 mm	8 mm
5650.64	64 mm	8 mm

D = diameter; H = height of the clamping disc.

Worked Sample

A clamping disc 5650.28 is pressurized with $p=10\text{N/mm}^2$ (100bar=1450psi). The resulting axial clamping force F_{ax} is

$$F_{ax}=p A=p \pi D^2 / 4=6158\text{N}$$

(Hint: 14.5psi=0,1N/mm²)

Operating conditions

All designs of the KOSTYRKA® clamping discs are intended for operation with pressure oil. However, they can in all cases be used with all liquid media to which the body and the seals are chemically and thermally resistant. These include hydraulic fluids and petroleum-based lubricants, transmission oils as well as animal and vegetable fats in the range -30°C to +110°C. Higher operating temperatures are possible with VITON® seals if required.

The maximum working pressure for KOSTYRKA® clamping discs is 450 bar. Contact our Development Department for details if you require higher pressures.

However, activation with oiled compressed air is possible for transmitting low forces.

Installation requirements

The overall height H is 8 mm for all clamping disc sizes. The depth of the locating hole must be at least 10 mm for all clamping disc sizes.

The surface roughness of the locating hole must not exceed $R_{\max} = 6 - 10\mu\text{m}$ ($R_a \leq 1.6\mu\text{m}$). It is essential to avoid grooves, particularly longitudinal grooves, in the bore-hole surface!

It is essential to make the diameter of the locating hole with the tolerance H7. A venting hole must be provided if several clamping discs are connected to each other via a bore-hole.

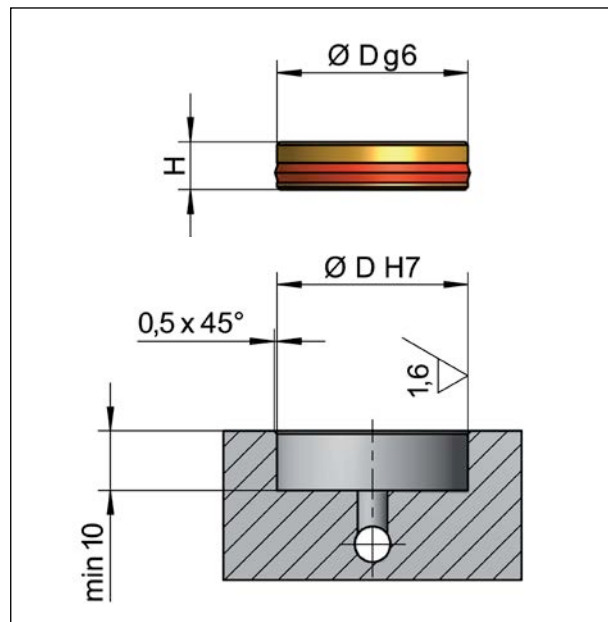

THE KOSTYRKA® CLAMPING CASSETTES.



The clamping strips that transmit the force are already integrated in KOSTYRKA® clamping cassettes.



KOSTYRKA® clamping cassette with annular piston for clamping turntables, swivel tables and milling heads.



KOSTYRKA® clamping cassette with clamping discs – custom solution for holding machining tables.

Sometimes, unfavourable space conditions can make the direct installation of clamping elements difficult if not impossible.

With KOSTYRKA® clamping cassettes, it is possible to mount a complete clamping device. The clamping strips and annular pistons that transmit the force are already integrated in the cassettes. In particular, the retrofilling of older machine tools to create modern, effective clamping elements is made much easier with KOSTYRKA clamping device. Since their design is tailored exclusively to meet the customer's specific requirements, standards from stock are not available. Contact our Development Department for details.

KOSTYRKA® CLAMPING RINGS.

The extensively tested KOSTYRKA® clamping rings are extremely efficient and compact clamping elements. They are used in mechanical engineering for, among other things, clamping turntables, swivel tables and milling heads.

Function

The bronze ring that has especially good spring properties and a clever shape is expanded by oil pressure and springs back into its original position when released.

Since the design of KOSTYRKA® clamping rings is tailored exclusively to meet the customer's specific requirements, standards from stock are not available. Contact our Development Department for details.

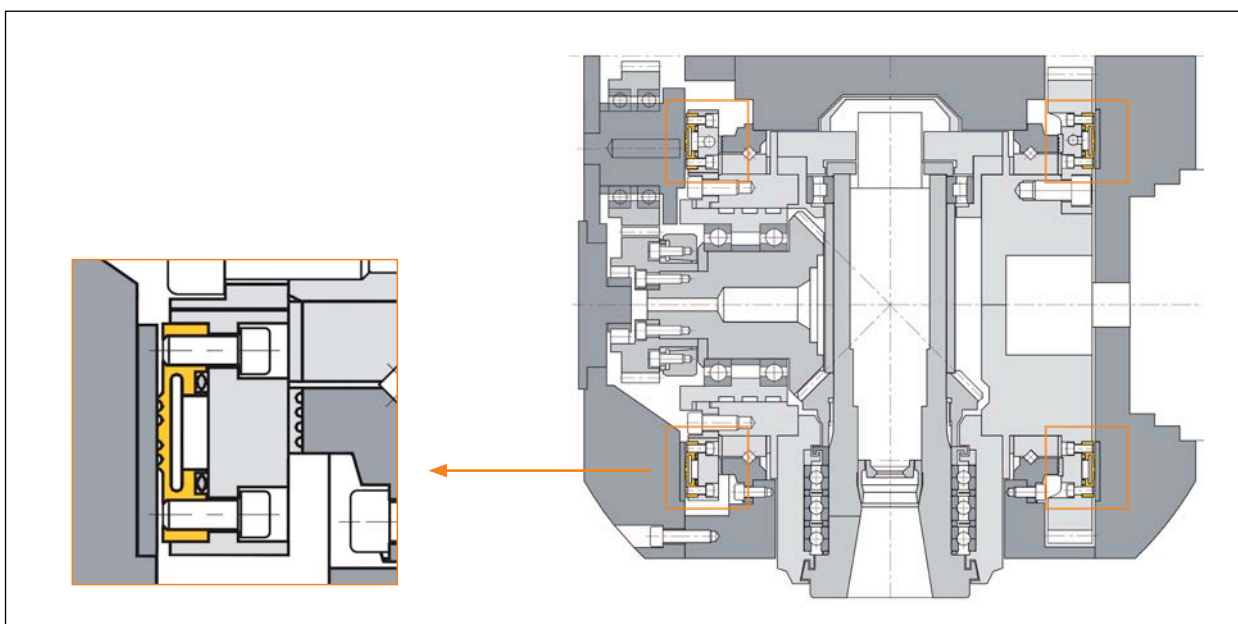

The example shows the clamping of a fork-type milling head.

EXAMPLES OF USE.

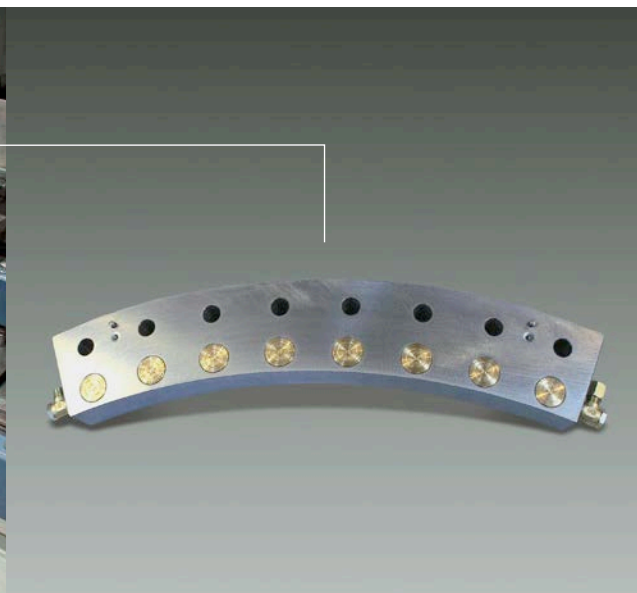

Segmented clamping cassettes with KOSTYRKA® clamping discs form an annular table clamp here.

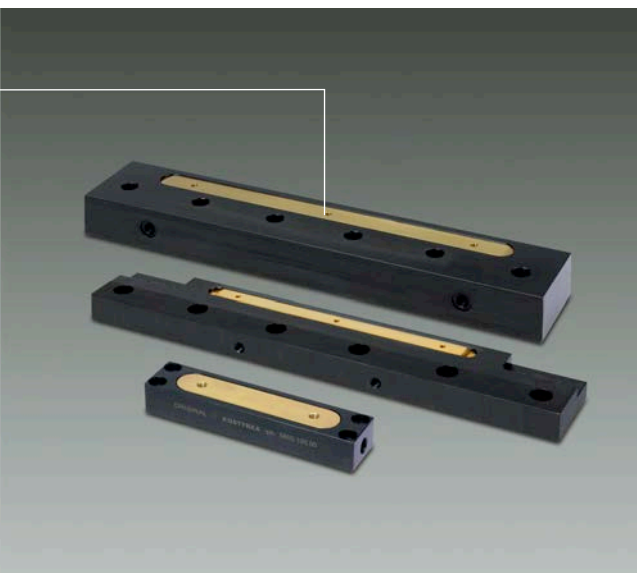

Ready-to-install, modular KOSTYRKA® clamping cassettes allow quick integration of the clamping unit into the machine.

ENGINEERING COMPETENCE.

Unmistakably secure, securely unmistakable

There's a very simple formula for KOSTYRKA quality: Install and forget. All KOSTYRKA products are designed to exceed the service lives of the machines in which they ensure smooth functioning.

Complete individual parts checking

The company meets the stringent demands that customers place on KOSTYRKA products by using state-of-the-art production and checking methods. This is how Kostyrka manufactures to tolerances that can be down into the 1,000ths range. And every single part that leaves a machine is thoroughly inspected to ensure dimensional accuracy.

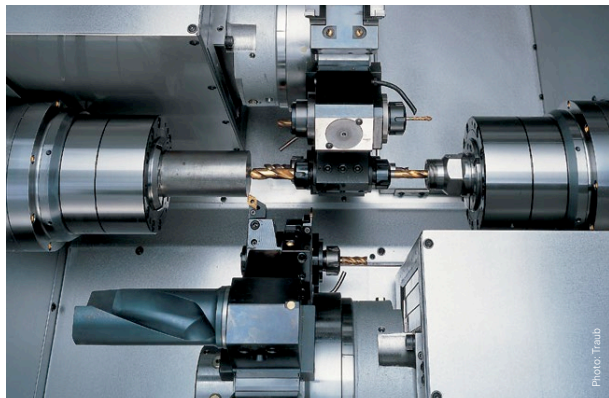

The headstock and tailstock clamps in Traub turning centres require holding times of up to 30 minutes and longer.



Oerlikon bevel gear cutting machines from Klingelberg. At Klingelberg, KOSTYRKA® clamping strips and clamping disks are used for a very wide range of tasks.

**Extract from the customer list**

ABB Robotics GmbH
Boeing Company, USA
Carl Zeiss Gruppe
Daimler AG
Deckel Maho Pfronten GmbH
Dörries Scharmann Technologie GmbH
Dr. Ing. h.c. F. Porsche AG
F. Zimmermann GmbH
FIBRO GmbH
Gebr. Heller Maschinenfabrik GmbH
General Electric Canada Inc., Kanada
GKN Aerospace GmbH
Hilti Aktiengesellschaft, Liechtenstein
Hyundai Motor Company, Süd Korea
INA Tooling Technique Pvt. Ltd., Indien
INDEX-Werke GmbH & Co. KG Hahn & Tessky
Israel Aerospace Industries Ltd., Israel
Japan Machinery Company Ltd., Japan
Lindauer DORNIER GmbH
MAN Nutzfahrzeuge Vertrieb GmbH
Maschinenfabrik Berthold Hermle AG
Robert Bosch GmbH
Romheld Automation Pty. Ltd., Australien
Schott AG
Siemens AG
StarragHeckert GmbH
Steinway & Sons Pianoforte-Fabrikanten
Swarovski AG, Österreich
ThyssenKrupp AG
Traub Drehmaschinen GmbH & Co. KG
TRUMPF GmbH + Co. KG
Waldrich Siegen Werkzeugmaschinen GmbH
ZF Friedrichshafen AG

KOSTYRKA GmbH

Dieselstraße 6
70839 Gerlingen
Germany

Phone +49 (0) 71 56 - 1 76 73-0
Fax +49 (0) 71 56 - 1 76 73-30

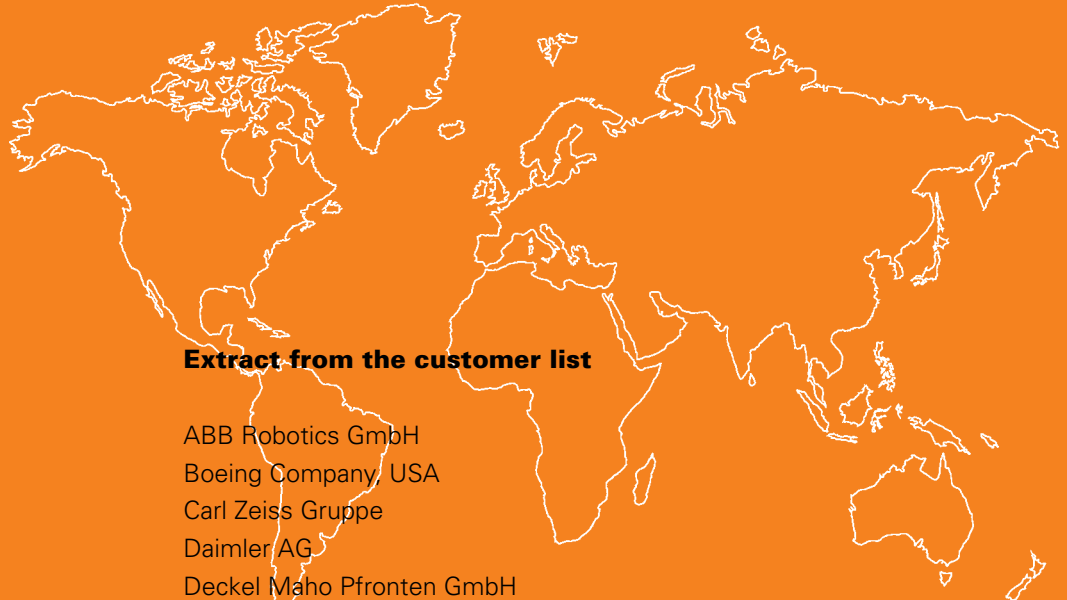
info@kostyrka.com
www.kostyrka.com