



HYDRAULIC  
PRESSURE  
INTENSIFIERS  
AIR-OIL  
AND OIL-OIL,  
SCREW PUMPS,  
SCREW PISTONS,  
PRESSURE  
ACCUMULATORS.



## THE ORIGINAL KOSTYRKA® HYDRAULIC PRESSURE INTENSIFIERS FOR AN OPTIMUM PRESSURE SUPPLY.

### **The principle: Turning low pressure into high pressure**

Many machine tools have either too-low hydraulic pressure or even none at all, only compressed air. This means that clamping fixtures on round and flat guides, as well as clamping and support elements in hydraulically actuated devices, cannot be operated.

The solution to these pressure problems: KOSTYRKA® hydraulic pressure intensifiers. A wide range of air-oil and oil-oil hydraulic pressure

intensifiers with many different transmission ratios ensures that high-pressure oil is available wherever it's needed – at low cost and without the need for additional maintenance work. The compact design of KOSTYRKA® hydraulic pressure intensifiers allows them to be installed even in tight spaces.

Besides the KOSTYRKA® hydraulic pressure intensifiers that are available from stock, KOSTYRKA also supplies customer-specific solutions. Contact our Development Department for details.



*KOSTYRKA® air-oil hydraulic pressure intensifier*



*KOSTYRKA® oil-oil hydraulic pressure intensifier*



*KOSTYRKA® screw pump*



*KOSTYRKA® screw piston*



*KOSTYRKA® pressure accumulator*

# KOSTYRKA® AIR-OIL HYDRAULIC PRESSURE INTENSIFIERS, SERIES 1410.

The KOSTYRKA® air-oil hydraulic pressure intensifiers of this series are primarily used where small amounts of high-pressure oil are needed, but where only compressed air is available.

Since October 2015, the proven KOSTYRKA® Series 1410 hydraulic pressure intensifiers have been supplied with an aluminum profile housing (exception 1410.10). Advantages here are reducing the weight and special versions to be realized quickly. In addition to mounting via a base plate, it is now also possible the threads on the front for mounting.

Furthermore it is possible to place a magnetic sensor into the grooves, and this can be used to detect the position of the intensification piston.

## Technical details and dimensions

Type no.	Type	Transmission ratio i	Displacement volume	Pneumatic return stroke
1410.10.00	Air-oil	1:12	5,0 ml	no
1410.20.00	Air-oil	1:34	6,2 ml	yes
1410.30.00	Air-oil	1:17	12,0 ml	yes
1410.35.00	Air-oil	1:51	15,0 ml	yes
1410.40.00	Air-oil	1:25	30,0 ml	yes

Standard sizes of the KOSTYRKA® air-oil hydraulic pressure intensifiers. **Working air pressure:** 3 - 7 bar · **Working fluid:** Hydraulic oils with a viscosity up to 32 mm<sup>2</sup>/s (32 cSt) at 40°C · **Installation position:** horizontal or upright, with the high-pressure section at the top.

It is essential to follow the operating instructions below to ensure perfect functioning:

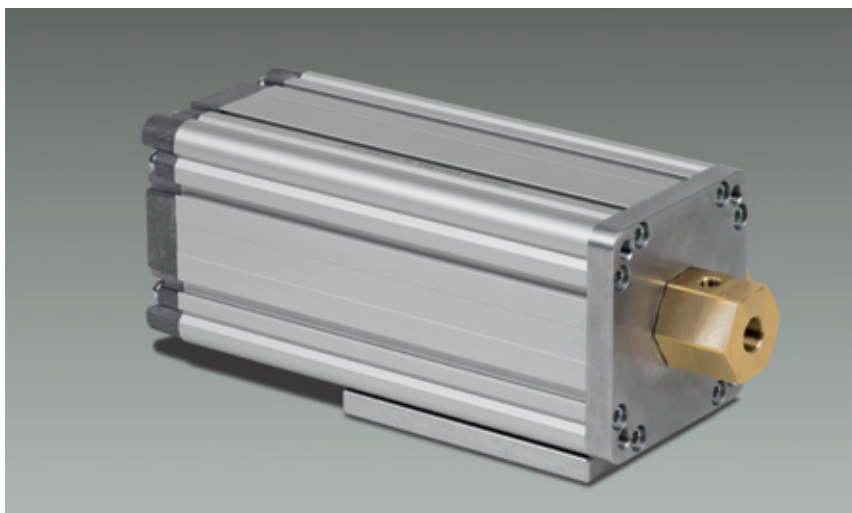

## Connection

On the pneumatic side, the hydraulic pressure intensifiers can be controlled via a single 2-way / 3-way valve. Due to the volume compression of the pressure oil (approx. 0.7% per 100 bar) that occurs in the entire high-pressure range, the shortest possible feed lines with a sufficient cross section should be used on the hydraulic side. Otherwise it may be that the displacement volume of the hydraulic pressure intensifier is not sufficient for perfect functioning of the consumer. We recommend screw connections with an O-ring seal on the front side.

**Caution:** Impurities in the pressure medium can impair the function! The step-seal gaskets should be replaced after approximately 300,000 operations!

## DIMENSIONS.



Dimensions Type  
1410.10  
This Type is the  
execution in steel.

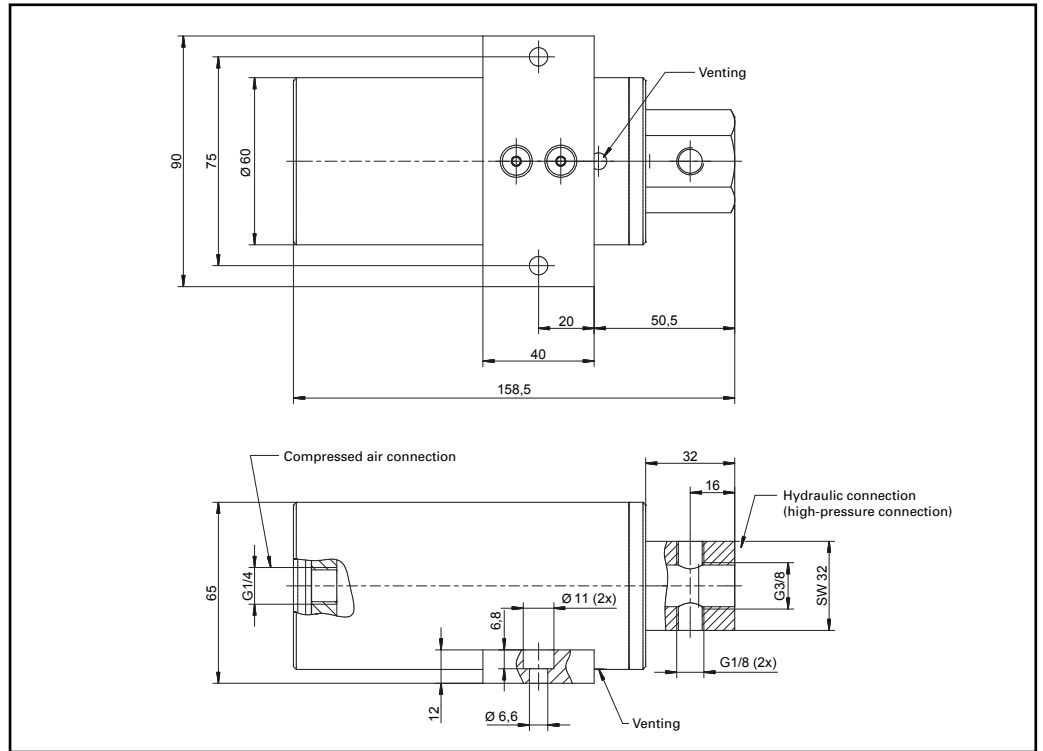

Dimensions  
Type 1410.20;  
Dimensions  
Type 1410.30  
in brackets.

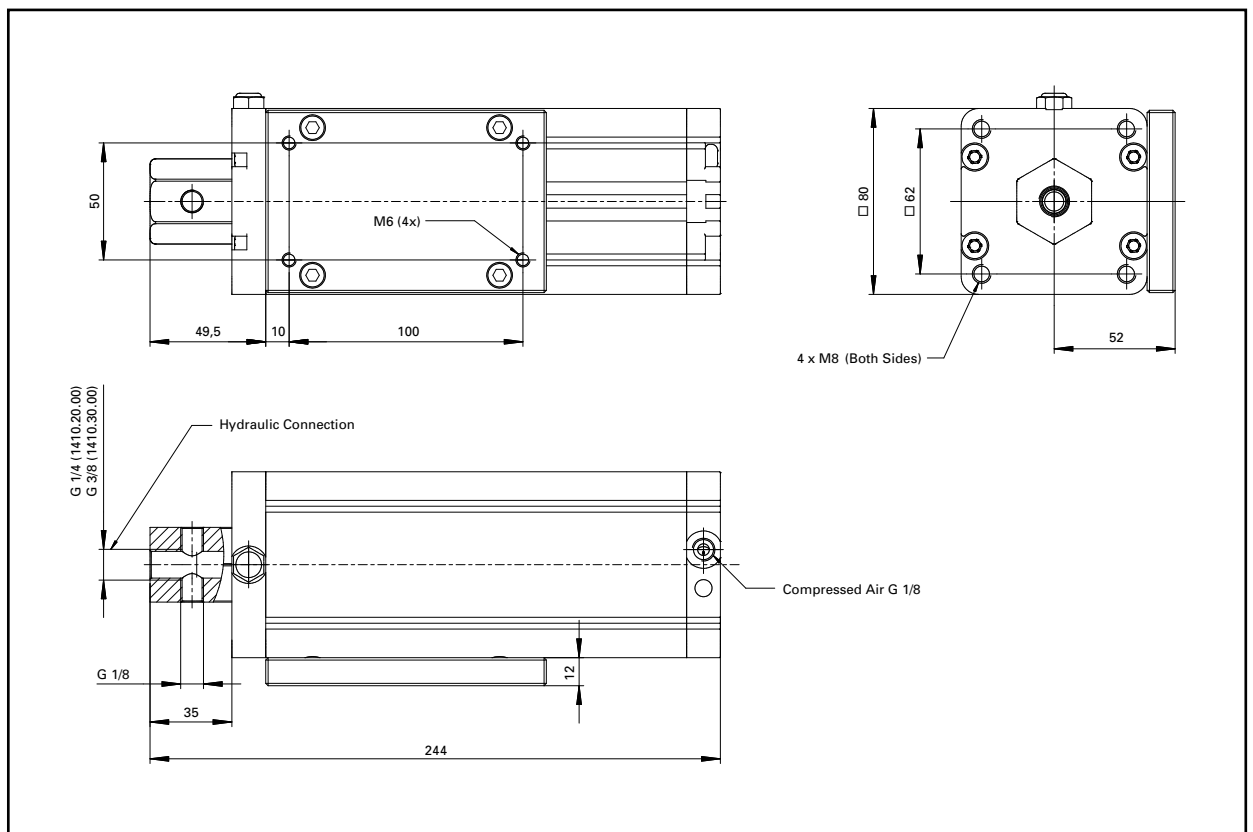

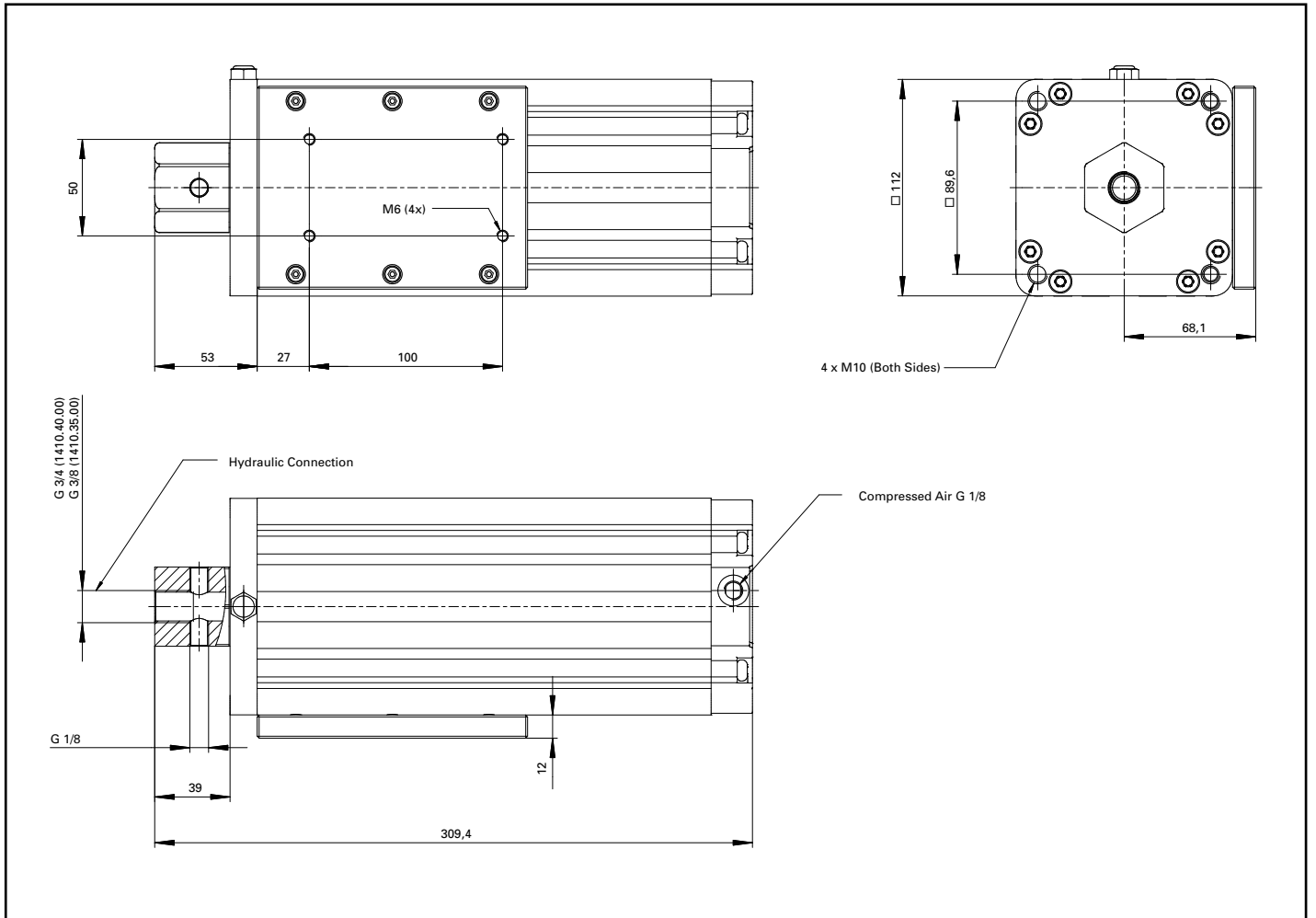

Dimensions Type 1410.35; Dimensions Type 1410.40 in brackets.

## Filling and Venting

Before first use, the hydraulic pressure intensifier must be filled with oil. For this, position the hydraulic pressure intensifier upright (oil port at the top, no pneumatic pressure present). Now fill the high-pressure cylinder up to the edge with oil. The connection to the consumer can now be made.

The limited-availability oil volume requires careful venting at the highest point of the hydraulic system. The automatic refilling and venting device 4610.10 can be installed here.

The two drawings below show the possible arrangements for KOSTYRKA® air-oil hydraulic pressure intensifiers and automatic refilling devices.

If the hydraulic pressure intensifier is located above the consumer, the pressure oil feed line must always open into the highest possible point of the oil chamber. The automatic refilling device can remain on the hydraulic pressure intensifier.

If the hydraulic pressure intensifier is installed below the consumers, the automatic refilling device must be disconnected from the pressure intensifier. In this case, the pressure oil feed line should run from the hydraulic pressure intensifier to the lowest point of the consumer and onward to the automatic refilling device (see figure below right).

It must be ensured that air pockets cannot be formed either in the feed lines or in the installation space of the sleeves. Compression causes air to heat up to such an extent that the sleeve material and seals could possibly be damaged.

Contact our Development Department for details.

*Hydraulic pressure intensifiers above the consumers.*

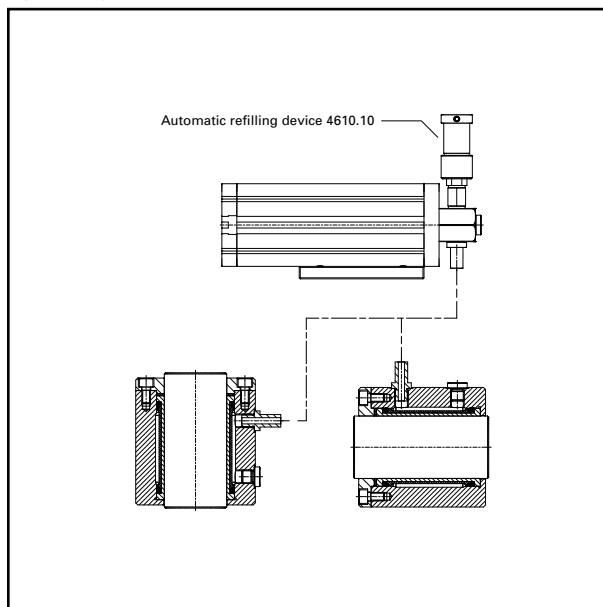

*Hydraulic pressure intensifiers below the consumers.*

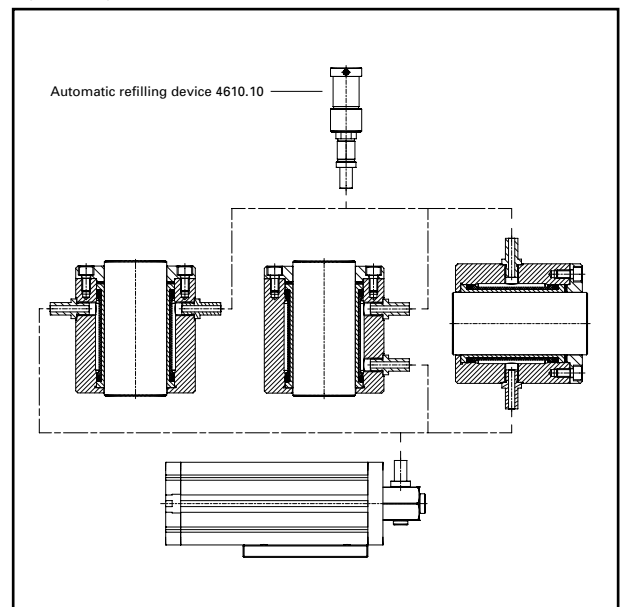

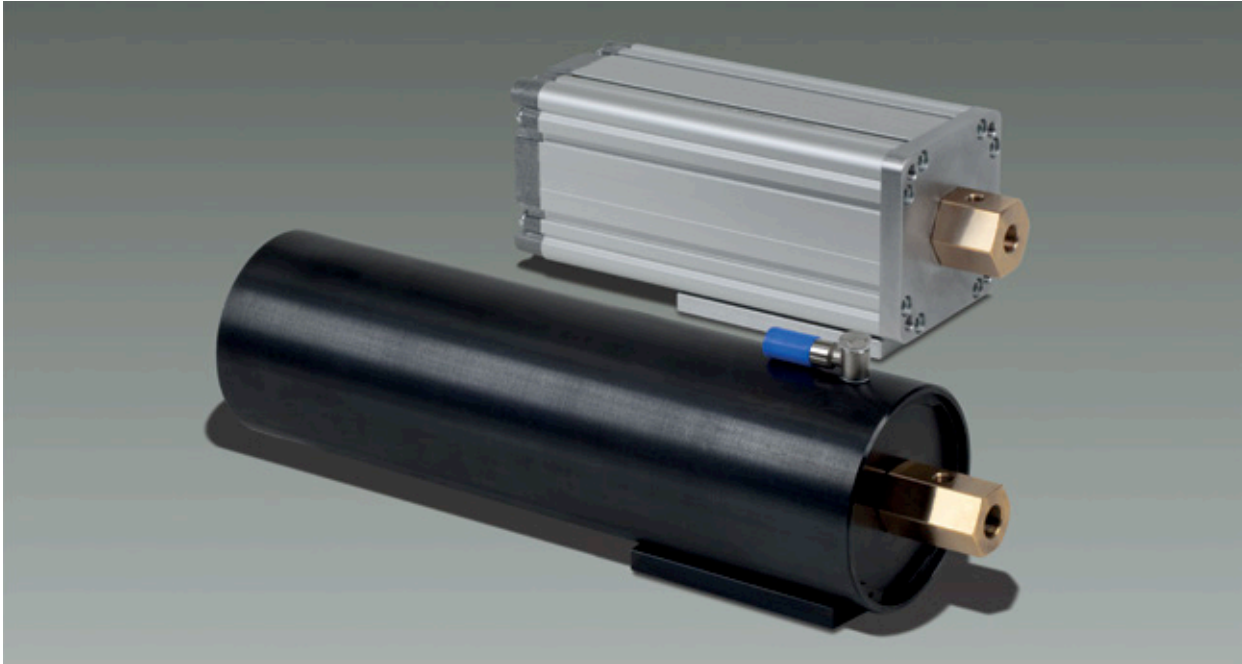

On request we can supply additional air-oil hydraulic pressure intensifiers with a very wide range of dimensions and transmission ratios. Contact our Development Department for details.

### Troubleshooting

Fault	Cause	Remedy
Hydraulic pressure intensifier builds up no or only very low pressure	Hydraulic pressure intensifier or the hydraulic pressure system not bled or is only incompletely bled	Vent at the highest point of the hydraulic pressure system
Hydraulic pressure intensifier builds up no or only very low pressure	Connecting lines too long or too flexible	Use the shortest possible high-pressure lines
Hydraulic pressure intensifier builds up no or only very low pressure	Not enough oil in the system	Hydraulic pressure intensifier must be completely filled with oil before installation
Hydraulic pressure intensifier builds up no or only very low pressure	The available oil volume of the hydraulic pressure intensifier is insufficient	Possibly use other hydraulic pressure intensifiers (please enquire)
Pressure on the high-pressure side drops in a short time	Hydraulic system leaking	Check for leaks, and seal
Sleeve (consumer) no longer opens	Residual pressure in the system	Slow the return stroke of the hydraulic pressure intensifier via a throttle valve (applies only in conjunction with automatic refilling device)

## KOSTYRKA® AUTOMATIC REFILLING DEVICE – AUTOMATIC VENTING, SERIES 4610.10.



The KOSTYRKA® automatic refilling device was specially developed for using KOSTYRKA® air-oil hydraulic pressure intensifiers.

In a closed high-pressure system, it is particularly important to ensure perfect and complete venting when the oil volume is limited. It is also necessary to compensate for drag oil losses, which are very minor but nevertheless noticeable over time. The KOSTYRKA® automatic refilling device 4610.10

*The KOSTYRKA® automatic refilling device can also be installed directly on the hydraulic pressure intensifier.*



meets both of these requirements. Installed at the highest point of the hydraulic system, it completely vents the entire system after only a short time. Provided that there are no „air traps“, the oil volume of the KOSTYRKA® air-oil hydraulic pressure intensifier can be used in its entirety.

### Set-up and function

The KOSTYRKA® automatic refilling device must be installed upright because of the way it works. When the hydraulic pressure is being built up in the system, the integrated valve closes immediately and seals hermetically so that the pressure can build up. When it is being relieved, the valve frees up the passage to the inspection glass once again and oil can flow into the hydraulic system.

**Caution:** Despite all protective measures, very small particles or suspended material can impair the valve function! When filling the automatic device, it is therefore essential to ensure absolute cleanliness of the hydraulic oil being used.

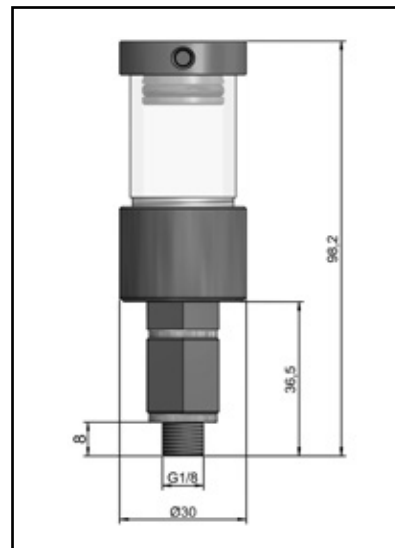

### Automatic refilling device 4610.10

*Pressure medium: Mineral oil-based hydraulic oils with a kinematic viscosity up to max. 32 mm<sup>2</sup>/s (32 cSt) at 40° C. Maximum pressure: 450 bar; Replenishment volume: 9 ml (20 ml or 66 ml on request); Installation position: Upright only, connection downwards.*



## KOSTYRKA® OIL-OIL HYDRAULIC PRESSURE INTENSIFIERS, SERIES 1450.

Often, machine tool construction as well as clamping and support elements in hydraulically actuated fixtures require higher pressures than those provided by the machine hydraulics. This is where KOSTYRKA® oil-oil hydraulic pressure intensifiers come in. The special characteristic of the Series 1450 KOSTYRKA® oil-oil hydraulic pressure intensifiers is their automatic refilling function. Any minor oil losses in the system's high-pressure section are automatically topped up from the feed line by a suction valve. A refill reservoir that requires constant monitoring is not needed here.

**Caution:** It is essential to make sure that the oil used is clean! Impurities in the pressure medium (suspended material, paint particles, adhesive residue, chips and similar) can prevent the installed suction valve from working!



### Technical details and dimensions

Type no.	Transmission ratio i	Displacement volume	Spring-loaded return stroke	Hydraulic return stroke	Working pressure	Working fluid	Installation position
1450.02	1:4	4 ml	yes	no	max. 100 bar on the low-pressure side	Hydraulic oils with a viscosity up to 32 mm/s (32 cSt) at 40°C	any
1450.04	1:4	15 ml	yes	yes			
1450.14	1:4	23 ml	no	yes			
1450.15	1:4	74 ml	no	yes			
1450.16	1:2,2	65 ml	no	yes			
1450.17	1:2,25	125 ml	no	yes			

*Subject to change.*

## DIMENSIONS.

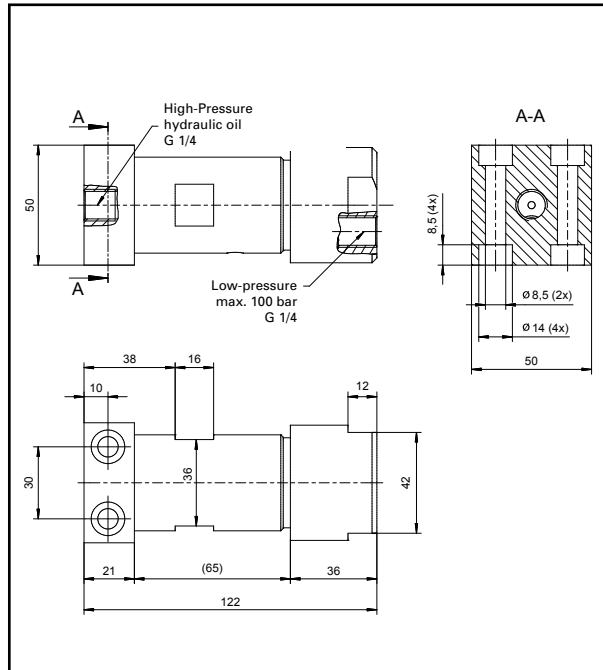

Dimensions Type 1450.02

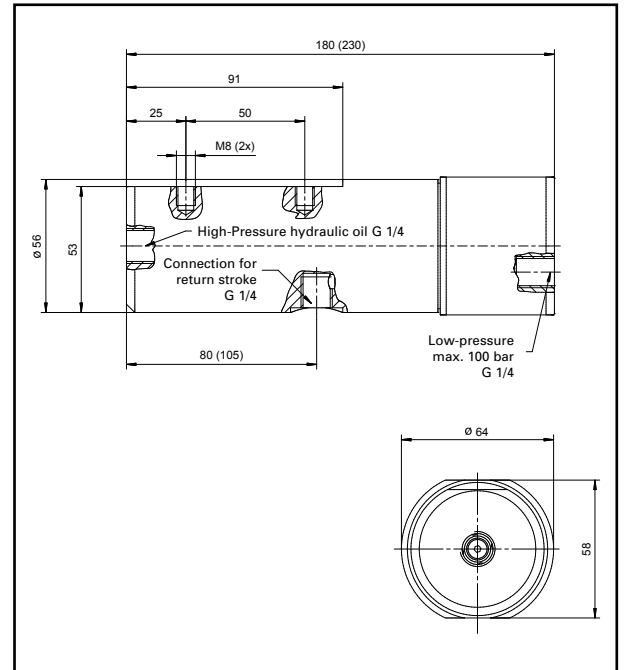

Dimensions Type 1450.04  
Dimensions Type 1450.14 in brackets.

### Type 1450.02

When small amounts of pressure oil are needed (for example for clamping individual clamping sleeves), it is advantageous to use the „Mini“ hydraulic pressure intensifiers 1450.02. Their small dimensions enable them to be mounted directly where the consumers are installed.

The KOSTYRKA® oil-oil hydraulic pressure intensifiers 1450.02 are supplied as single-acting units (with built-in return spring).

**Caution:** The comparatively low useful oil volume requires particularly careful venting of the high-pressure chamber and short feed lines. Rigid connections between the pressure intensifier and the oil chamber have proved to be particularly successful.

### Types 1450.04 and 1450.14

The KOSTYRKA® oil-oil hydraulic pressure intensifiers 1450.04 are also supplied as single-acting units (with built-in return spring). To speed up the return stroke, for example where the feed or pressure lines are very long, the pressure intensifier piston can also be returned hydraulically via an additional connection.

**Caution:** KOSTYRKA® Type 1450.14 oil-oil hydraulic pressure intensifiers are supplied exclusively as a double acting design (without piston return spring).

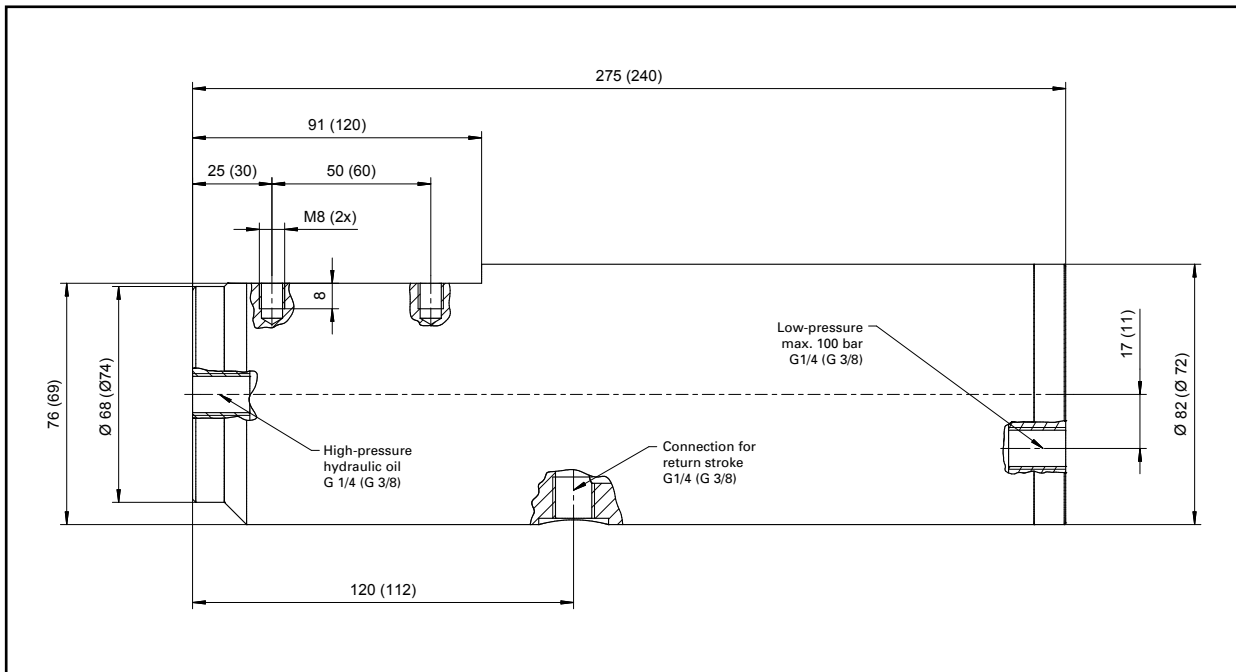

Dimensions Type 1450.15 and 1450.17;  
Dimensions Type 1450.16 in brackets.

### Types 1450.15 and 1450.17

The configuration of KOSTYRKA® oil-oil hydraulic pressure intensifiers 1450.15 ( $i= 1:4$ ) and 1450.17 ( $i= 1:2,25$ ) is the same as Types 1450.04 and 1450.14, but they have a significantly greater useful oil volume. With these hydraulic pressure intensifiers, it is possible to operate a greater number of clamping sleeves, clamping strips or clamping discs simultaneously.

KOSTYRKA® Type 1450.15 and 1450.17 oil-oil hydraulic pressure intensifiers are supplied exclusively as a double acting design (without piston return spring).

### Type 1450.16

Besides the greater useful oil volume, the low transmission ratio is another stand-out feature of the KOSTYRKA® oil-oil hydraulic pressure intensifier 1450.16 ( $i= 1:2,2$ ). Sufficient for many purposes, this element forms a small and maintenance-free hydraulic pressure unit. This type of hydraulic pressure intensifier is also only supplied as a double acting version (without piston return spring).

It is essential to follow the operating instructions below to ensure perfect functioning:

### Filling and venting

For easier operation, it is possible to fill both the low-pressure side and the high-pressure side with oil on the hydraulic pressure intensifier before connecting the lines. When doing so, it is essential to make sure that the piston is in its home position. If necessary, carefully push the piston down from the high-pressure side with e.g. a screwdriver. To fill the hydraulic pressure intensifier, it is essential to position it upright and fill it with oil through the open connection. Before turning the hydraulic pressure intensifier, connect the corresponding line in order to prevent the oil from escaping.

The hydraulic pressure intensifiers allow a regulated oil flow in the low pressure to high pressure direction for as long as the high-pressure part of the complete system is not closed. To vent, open the highest connection of the high-pressure system while the low-pressure system is delivering flow.

When doing this, keep the pressure as low as possible. If the pressure is too high, the piston can move out of its home position and thereby close the suction valve. When oil emerges with no bubbles, close this opening. Do not stop the low-pressure system from delivering flow until then.

### Connection

Due to the volume compression of the pressure oil (approx. 0.7% per 100 bar) that occurs in the entire high-pressure range, the shortest possible feed lines should be used. Otherwise, the displacement volume may be insufficient for perfect functioning.

### Customer-specific solutions

On request we can supply additional oil-oil hydraulic pressure intensifiers with a very wide range of dimensions and transmission ratios. Contact our Development Department for details.

### Troubleshooting

Fault	Cause	Remedy
The hydraulic pressure intensifier builds up no or only very low pressure	Hydraulic pressure intensifier or the hydraulic pressure system not vent or is only incompletely vent	Vent at the highest point of the hydraulic pressure system
The hydraulic pressure intensifier builds up no or only very low pressure	The additional connection for the low-pressure return is closed	In the case of Type 1450.04, this connection must remain open if it is not used
The hydraulic pressure intensifier builds up no or only very low pressure	Impurities in the area of the suction valve impair its function	Open the hydraulic pressure intensifier and carefully pull out the piston. Clean with compressed air. Pay attention to the seals when assembling
The hydraulic pressure intensifier builds up only very low pressure on the high-pressure side	Connecting lines too long or too flexible	Use the shortest possible high-pressure lines (see the point Connection)

## KOSTYRKA® SERIES 1221 SCREW PISTONS.

KOSTYRKA® screw pistons allow pressure oil to be produced by simple screwing in using an Allen key. The screw pistons are supplied ready to install and should preferably be installed directly in the prepared holes in the fixture body or machine body. The very long piston is hardened and ground. A setscrew serving as a pressure spindle runs in bronze. A hardened steel ball on the piston base ensures low-friction, controlled force transmission.

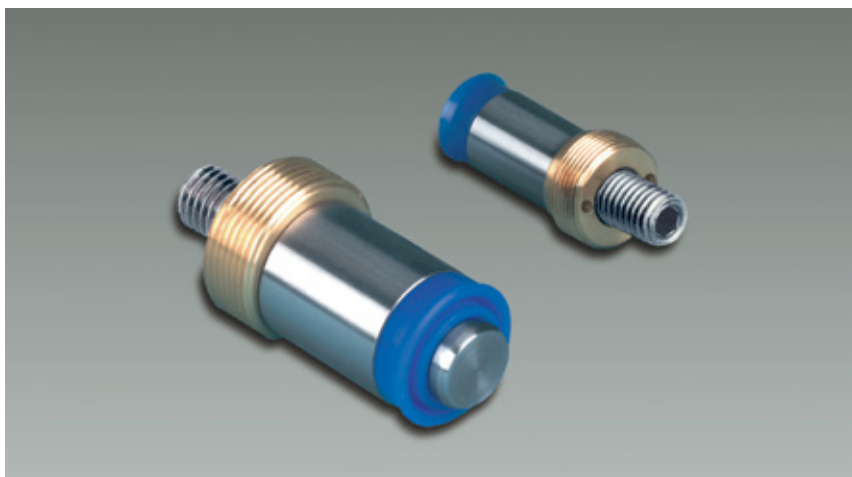

### Technical details and dimensions

Typ	G1	G2	G3	d1	d2	L	L1	L2	L3	L4	s	H	V
1221.16	M20 x 1,0	M10 x 35	M12	16	18	41	10	31	2	12	5	15	3
1221.25	M30 x 1,5	M12 x 50	M16	25	-	52	12	40	-	15	6	25	12

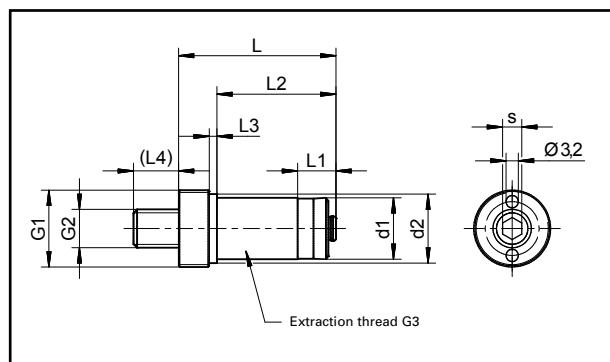

Dimensions Series 1221 screw pistons.

G2 = setscrew DIN 913 (the piston stroke H can be increased by installing a longer setscrew; in that case, adjust the depth 47 (65) of the locating hole accordingly) / H = usable piston stroke / V = oil displacement (ml) at piston stroke H. Dimensions in mm. Subject to change.

### Locating holes for Type 1221.16 and 1221.25 screw pistons

It is essential to configure the locating holes for the aforementioned screw pistons as shown here besides.

To avoid damaging the sealing lips during installation, it is essential to give the hole a sufficiently large, rounded 20° lead chamfer. The displacement volume V can be increased by adjusting the hole depth 47(65) accordingly and using longer setscrews G2.

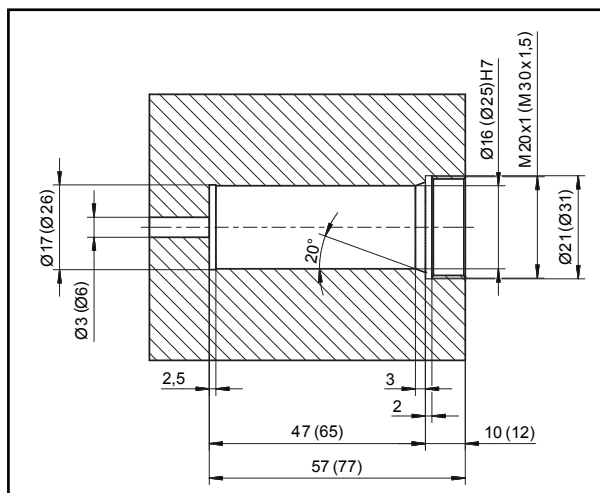

Dimensions location holes for Type 1221.16 and 1221.25 (in brackets).

## KOSTYRKA® SERIES 1220 SCREW PUMPS.



### Example of use

A screw pump actuates the KOSTYRKA® hydraulic support unit 5310.30. There is no need for the pressure lines and the external pump that are otherwise required.

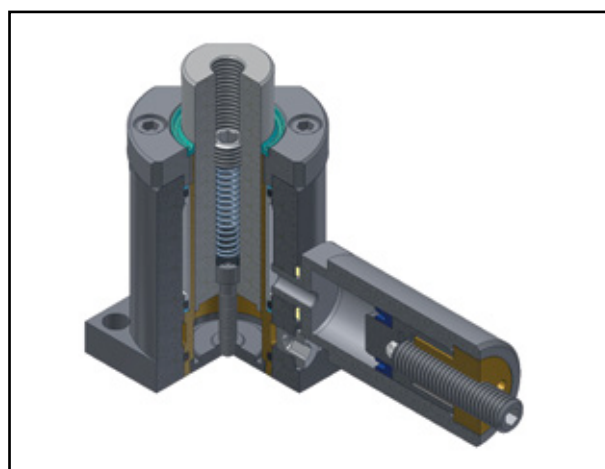

Example of use.

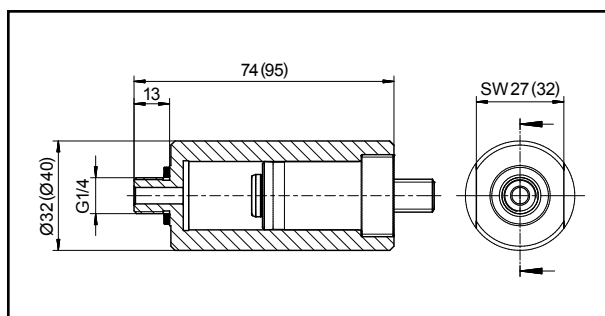

Dimensions Type 1221.16;  
Dimensions Type 2121.25 in brackets.

The KOSTYRKA® screw pistons 1221.16 and 1221.25 are also supplied as complete screw pumps. For this, the screw pistons are installed in suitable housings that can be screwed directly into the G1/4 connection holes.

### Pressure flow

With the setscrew of the KOSTYRKA® screw piston lubricated with grease, the diagram shows the approximate relationship between the applied tightening torque and the oil pressure generated. A MoS<sub>2</sub>-based lubricant can improve efficiency still further.

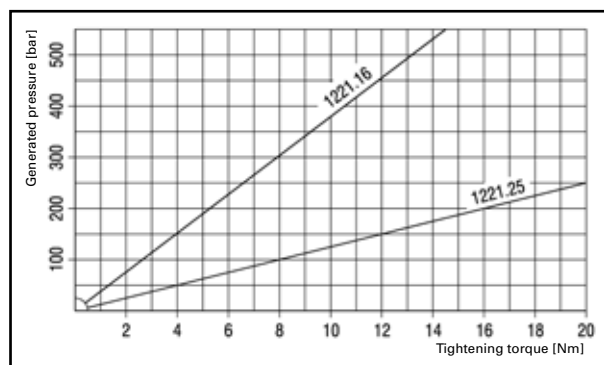

Relationship between the applied tightening torque and the oil pressure.

Customer-specific solutions are always possible. Contact our Development Department for details.

## KOSTYRKA® SERIES 1480 PRESSURE ACCUMULATORS.

The KOSTYRKA® pressure accumulator was developed specially for use with the proven KOSTYRKA clamping elements. Its core is a gas pressure spring element that generates the respective hydraulic pressure. Advantage: The stored energy is even available if the primary energy fails. This maintains the holding force and the holding torque in the KOSTYRKA clamping elements. The KOSTYRKA® oil-oil or air-oil hydraulic pressure generators are used for releasing.

### Advantages of the pressure accumulator

- Safety if the primary energy fails
- Energy saving
- Retrofittable

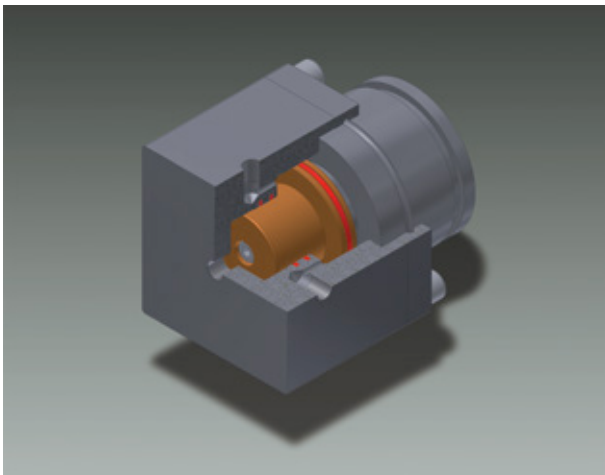

Pressure accumulator 1480.01					
	Primary side		Secondary side		
Type no.	Release pressure	Release volume	$P_{min}$	$P_{max}$	Volume
1480.01.050	71 bar	26 ml	71 bar	93 bar	19 ml
1480.01.080	111 bar	26 ml	112 bar	146 bar	19 ml
1480.01.100	141 bar	26 ml	143 bar	185 bar	19 ml
1480.01.120	169 bar	26 ml	171 bar	222 bar	19 ml
1480.01.150	210 bar	26 ml	211 bar	275 bar	19 ml

Other sizes on request.

**Extract from the customer list**

ABB Robotics GmbH  
Boeing Company, USA  
Carl Zeiss Gruppe  
Daimler AG  
Deckel Maho Pfronten GmbH  
Dörries Scharmann Technologie GmbH  
Dr. Ing. h.c. F. Porsche AG  
F. Zimmermann GmbH  
FIBRO GmbH  
Gebr. Heller Maschinenfabrik GmbH  
General Electric Canada Inc., Kanada  
GKN Aerospace GmbH  
Hilti Aktiengesellschaft, Liechtenstein  
Hyundai Motor Company, Süd Korea  
INA Tooling Technique Pvt. Ltd., Indien  
INDEX-Werke GmbH & Co. KG Hahn & Tessky  
Israel Aerospace Industries Ltd., Israel  
Japan Machinery Company Ltd., Japan  
Lindauer DORNIER GmbH  
MAN Nutzfahrzeuge Vertrieb GmbH  
Maschinenfabrik Berthold Hermle AG  
Robert Bosch GmbH  
Romheld Automation Pty. Ltd., Australien  
Schott AG  
Siemens AG  
StarragHeckert GmbH  
Steinway & Sons Pianoforte-Fabrikanten  
Swarovski AG, Österreich  
ThyssenKrupp AG  
Traub Drehmaschinen GmbH & Co. KG  
TRUMPF GmbH + Co. KG  
Waldrich Siegen Werkzeugmaschinen GmbH  
ZF Friedrichshafen AG

**KOSTYRKA GmbH**

Dieselstraße 6  
70839 Gerlingen  
Germany

Phone +49 (0) 71 56 - 1 76 73-0  
Fax +49 (0) 71 56 - 1 76 73-30

info@kostyrka.com  
www.kostyrka.com