

## Threaded Lock Pins • self-locking

EH 22355.



## Product Description

Threaded lock pins are used for quick fastening, locking, adjusting, changing and securing. Quickly and easily unlockable for frequently repeated connections.

By pressing the button, the threaded segments unlock and the threaded lock pin can be inserted into or removed from a threaded hole. A time-consuming screwing in and out is unnecessary.

The threaded lock pin is characterised by the following features:

- corrosion-protected
- no time-consuming screwing in and out
- self-locking due to spring load

## Material

## Pin part

- Stainless Steel

## Handle

- Thermoplastic PA 6, black, dull similar to RAL 9005

## Press button

- Aluminium, orange, anodised

## Threaded element

- Stainless steel 1.4542, precipitation-hardened

## Spring

- Stainless Steel

## Assembly

Threaded lock pins can only be mounted into a thread that is true to gauge.

## Mounting:

1. Press in the button and hold it down.
2. Insert the threaded lock pin.
3. Release the button (The button must be back in its original position.).
4. Tighten the threaded lock pin by hand as required.
5. It must be ensured that the threaded segments are engaged in the mounting thread.

## Dismantling:

1. Unscrew the threaded lock pin approx. a quarter of a turn anticlockwise.
2. Press in the button and hold it down.
3. Remove the threaded lock pin.
4. Release the button.

## Operation

The threaded segments are unlocked by pressing the button.

## More information

## Notes

Special types on request.

## Accessories

Can easily be fitted with retaining cable EH 22355.

## Further products

- Threaded Lock Pins, self-locking, with axial bearing
- Retaining Cables, for threaded lock pin

## Drawing

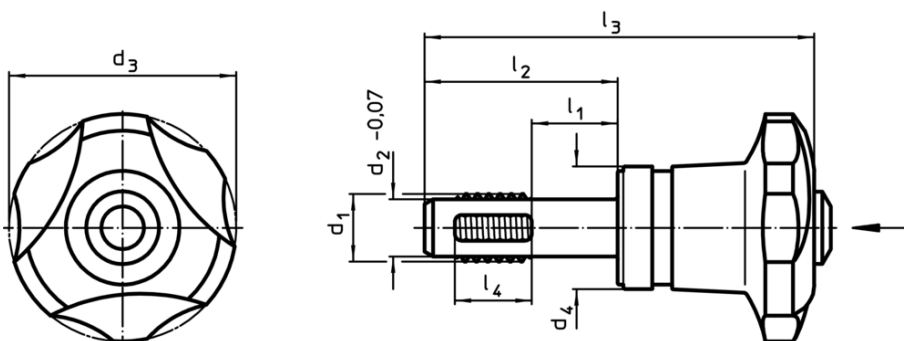

Order information

d <sub>1</sub>	l <sub>1</sub>	Dimensions						Locating thread	Temperature		Tightening torque max.	Clamping force max.	Established tightening torque ~ <sup>1)</sup>	Clamping force ~ <sup>2)</sup>	Weight	Shearing resistance, two-shear <sup>3)</sup> min.	Art. No.
		d <sub>2</sub> -0.07	d <sub>3</sub> -1	d <sub>4</sub>	l <sub>2</sub>	l <sub>3</sub>	l <sub>4</sub>		min.	max.							
[mm]							[mm]	[°C]		[Nm]	[kN]	[Nm]	[kN]	[g]	[kN]		
M 8	10	6.62	40	21.6	23.8	58.4	8	M 8	-30	80	5	3.3	3.5	2.3	86	12.7	22355.0102
M 8	20	6.62	40	21.6	33.8	68.4	8	M 8	-30	80	5	3.3	3.5	2.3	90	12.7	22355.0104
M 8	30	6.62	40	21.6	43.8	78.4	8	M 8	-30	80	5	3.3	3.5	2.3	93	12.7	22355.0106
M10	10	8.35	40	21.6	26.0	60.6	10	M10	-30	80	5	2.9	3.5	2.0	93	20.6	22355.0202
M10	20	8.35	40	21.6	36.0	70.6	10	M10	-30	80	5	2.9	3.5	2.0	94	20.6	22355.0204
M10	30	8.35	40	21.6	46.0	80.6	10	M10	-30	80	5	2.9	3.5	2.0	99	20.6	22355.0206
M12	15	10.07	40	21.6	34.0	68.6	12	M12	-30	80	5	2.5	3.5	1.8	99	30.4	22355.0303
M12	30	10.07	40	21.6	49.0	83.6	12	M12	-30	80	5	2.5	3.5	1.8	108	30.4	22355.0306
M12	50	10.07	40	21.6	69.0	103.6	12	M12	-30	80	5	2.5	3.5	1.8	122	30.4	22355.0310
M16	15	13.80	40	21.6	34.0	68.6	12	M16	-30	80	5	2.1	3.5	1.5	116	62.9	22355.0503
M16	30	13.80	40	21.6	49.0	83.6	12	M16	-30	80	5	2.1	3.5	1.5	133	62.9	22355.0506
M16	50	13.80	40	21.6	69.0	103.6	12	M16	-30	80	5	2.1	3.5	1.5	155	62.9	22355.0510
<b>Stainless Steel</b>																	
M 8	10	6.62	40	21.6	23.8	58.4	8	M 8	-30	80	5	3.3	3.5	2.3	88	16.7	22355.1102
M 8	20	6.62	40	21.6	33.8	68.4	8	M 8	-30	80	5	3.3	3.5	2.3	90	16.7	22355.1104
M 8	30	6.62	40	21.6	43.8	78.4	8	M 8	-30	80	5	3.3	3.5	2.3	92	16.7	22355.1106
M10	10	8.35	40	21.6	26.0	60.6	10	M10	-30	80	5	2.9	3.5	2.0	91	27.1	22355.1202
M10	20	8.35	40	21.6	36.0	70.6	10	M10	-30	80	5	2.9	3.5	2.0	95	27.1	22355.1204
M10	30	8.35	40	21.6	46.0	80.6	10	M10	-30	80	5	2.9	3.5	2.0	120	27.1	22355.1206
M12	15	10.07	40	21.6	34.0	68.6	12	M12	-30	80	5	2.5	3.5	1.8	100	40.0	22355.1303
M12	30	10.07	40	21.6	49.0	83.6	12	M12	-30	80	5	2.5	3.5	1.8	109	40.0	22355.1306
M12	50	10.07	40	21.6	69.0	103.6	12	M12	-30	80	5	2.5	3.5	1.8	120	40.0	22355.1310
M16	15	13.80	40	21.6	34.0	68.6	12	M16	-30	80	5	2.1	3.5	1.5	115	82.7	22355.1503
M16	30	13.80	40	21.6	49.0	83.6	12	M16	-30	80	5	2.1	3.5	1.5	133	82.7	22355.1506
M16	50	13.80	40	21.6	69.0	103.6	12	M16	-30	80	5	2.1	3.5	1.5	156	82.7	22355.1510

<sup>1)</sup> Average hand force established in trials.

<sup>2)</sup> Average value established in trials.

<sup>3)</sup> Shearing resistance similar to DIN 50141; values apply to applications in plugged condition (without applied tightening torque).

Application example

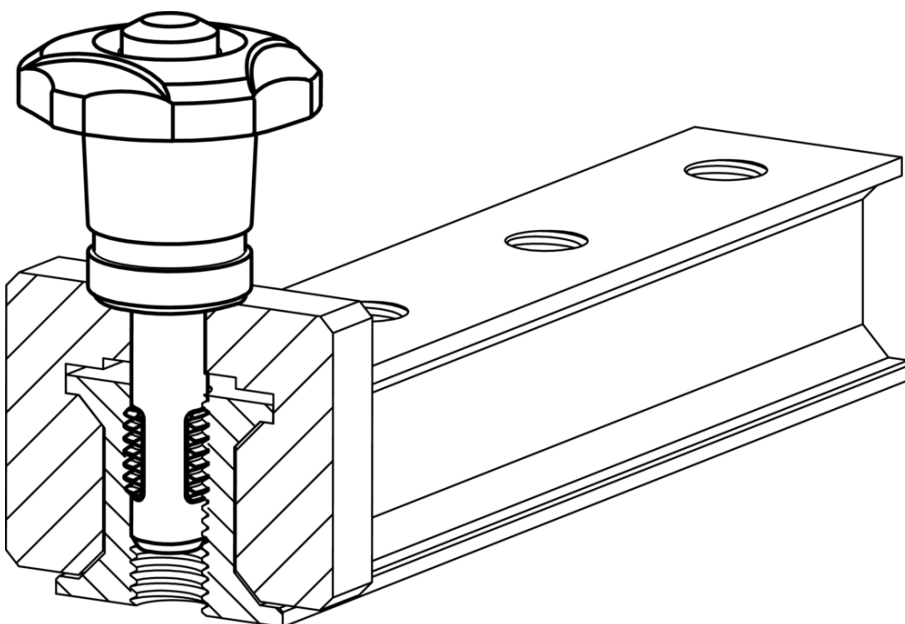

## Compliance

### RoHS compliant

Contains lead - compliant according to exceptions 6a / 6b / 6c

### Contains SVHC substances >0,1% w/w

Contains lead - SVHC list [REACH] as of 10.06.2022

### Contains Proposition 65 substances



Lead can cause cancer and reproductive harm from exposure  
<https://www.P65Warnings.ca.gov/>

### Free from Conflict Minerals

This product does not contain any substances designated as "conflict minerals" such as tantalum, tin, gold or tungsten from the Democratic Republic of Congo or adjacent countries.